

K9-P DINGO MINI LOADER

The Ozzy Dingo K9-P is our only petrol machine, but it is no ordinary petrol because it is the new Kohler EFI engine- a far superior animal to any carburetted engine. And the next best thing to diesel technology.

The K9-P will replace our previous 950, K93 and All-Rounder petrol machines, but is far more superior. Cast chassis, higher lift height, heavier duty, bigger hydraulics, etc. But still handles all the same attachment range.

The K9-P is the preferred mini digger of the hire industry and trusted by thousands of owners around Australia. The Dingo K9-P is the ultimate no nonsense rugged Dingo combining some of the great features of the range topping CONTRACTOR with the tried & tested reliability of the ever popular All-Rounder.

SPECIFICATIONS

Engine

Make	Kohler (Petrol EFI)
Power	23hp (17kw)
RPM	3600

Performance

Hydraulic Pumps	2 Pumps
Pump Sizes	11 & 4cc
Relief Pressure (Aux)	3200psi (220bar)
Hydraulic Output	47L/m
Max Travel Speed	7.5km/h
Rated Lift Capacity	325kg WLL 600kg MLL
Wheel Motors	4
Aux Hydraulic Outlets	1

Standard Features

- 2 pump hydraulic system
- 4 x Auxiliary outlets
- Flow controller (trenching valve)
- AWD System
- Heavy duty air cleaner & pre cleaner
- Hard wearing Dingo tyres
- Quick hitch system
- Superior Aust. Made - 4 Core 3 Pass Radiator
- Soft touch controls
- Tuff powder - coated finish
- LED headlights
- High Flow Oil cooler

Safety Features

- Solid & wide operators platform
- Low centre of gravity & excellent stability
- Hydraulic relief valves
- Concealed rupture resistant plastic fuel tank
- Reduced engine noise
- Proper handle bars
- Battery isolator & remote jump point

Dimensions

A. Overall Width	1035mm
B. Overall Length	1600mm
C. Overall Height	1200mm
D. Max operating height 4in1	2645mm
E. Turning Radius with 4in1 Bucket	1300mm
F. Angle of Departure	25°
G. Wheel Base	800mm
H. Ground Clearance	135mm
I. Dump Height Std Bucket	1450mm
J. Dump Height 4in1 Bucket	1835mm
K. Reach Fully Raised 4in1 Bucket	800mm
L. Height to Hinge Pin	1940mm
M. Machine width 4in1 bucket	1050 - 1200mm

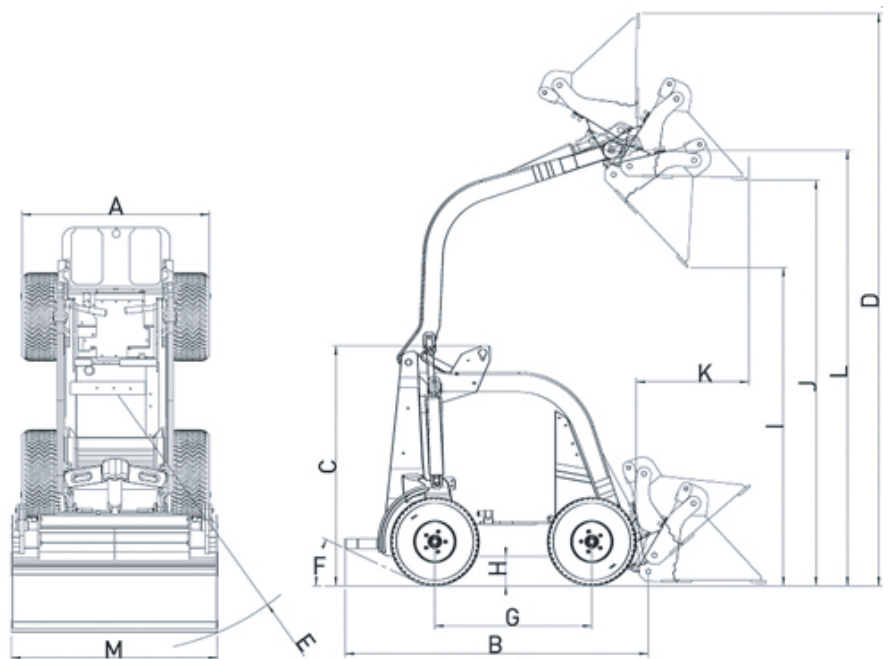

Hydraulic Reservoir Capacity 76L
Machine Mass 862kg